

NP-SC100100HM X-Ray Security Inspection System

NP-SC100100HM X-Ray security inspection system is an advanced security detection system designed for briefcases, postal bags, express mails, hand held parcels, and small packages checking with a world leading x-ray screening and high resolution & multi-energy image processing technology. With the popular tunnel size of about 1000mm (W) x 1000mm (H), compact and movable design, NP-SC100100HM is an high level security inspection solution for hotels, government agencies, transportation hubs, logistics industry, courts, prosecutors, prisons, embassies, factories, schools, hospitals, stadiums, exhibition halls, entertainment venues, etc. It is suitable for both hand held and holding baggage screening.



Key Features

- High performance with HD image, strong penetration, precise recognition
- Adopts windows operating system
- Energy saving and environment protection with low power consumption
- Supports real-time monitoring
- Supports multiple image processing mode
- Supports POST (power on self-test)
- 64X zoom in
- One-touch power off
- Energy-saving working mode for conveyor available
- Shock-proof design
- User friendly interface for easy operation

System Functions

X-ray Image processing functions: Color/Black & White, local enhancement, high penetration, low penetration, super enhancement, organic stripping, inorganic stripping, inverse color, light increase, light reduce, grey scale scan, image zoom in, Pseudo Color, organic enhancement, suspicious threat mark alarm, edge enhancement.

System functions: Power on self-diagnosis, multi levels user management, image management, TIP management, curve diagnosis, key board diagnosis, equipment information query, Multi-format image export, OSD operation function, image mirroring, 1-64 times stepless zoom in, magnifying glass, operator training, precise positioning of baggage images, clear channel reminder, one-key shutdown



Specifications

Model	NP-SC100100HM
Tunnel size	1008mm W x1011mm H
Conveyor speed	0.22 m/s
Conveyor height	340.5mm
Max. load	200 kg (440.92 lb)
Penetration (steel)	Standard 34mm, 40+ mm available by customize
Wire resolution	36AWG
Spatial resolution	Vertical: 1.3 mm; Horizontal: 1.3 mm
X-ray dose per inspection	< 4 μ Sv
X-ray leakage	< 1 μ Sv/h
X-ray generator	Anode Voltage: 160 kV, 100% Oil Cooling, Single generator, vertical beam direction.
Images colors	B/W, Colors
Images storage	10000 images
Film safety	ISO1600
Working temperature	5 °C to 40 ° C (41 °F to 104 °F)
Working humidity	0% to 90%
Operating System	Windows
Power supply	AC 220 V (+ 10% to -15%), 50 Hz (\pm 3 Hz)
Power consumption	1 kw
Dimension (L x W x H) without table	3644.5mm x1295 mm x 1922 mm (143.48" x 50.98" x75.67")
Weight	1080 kg (2380.99 lb)
Extended table	1220mm
Accessories	
Extended table	1220mm x1 in exit (Included)
LCD monitor	17" LCD Color Monitor x2 included
Operation desk	X1 set included
Dedicated Key board & mouse	Standard included

Dimension

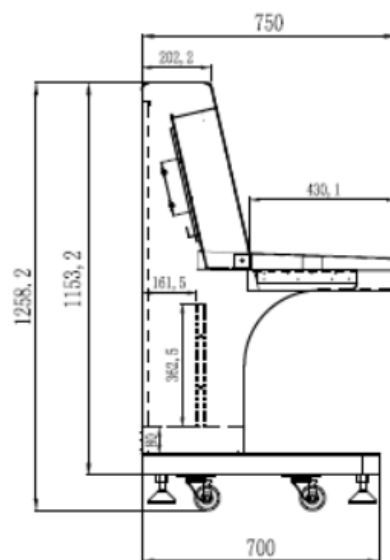
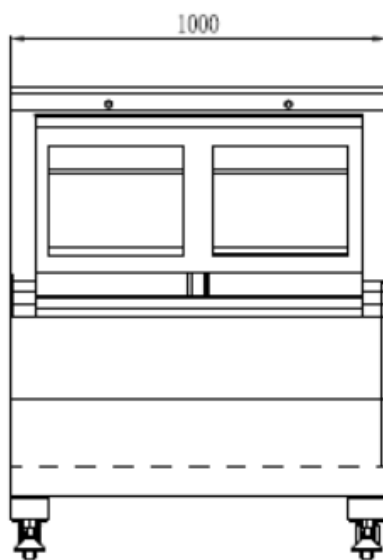
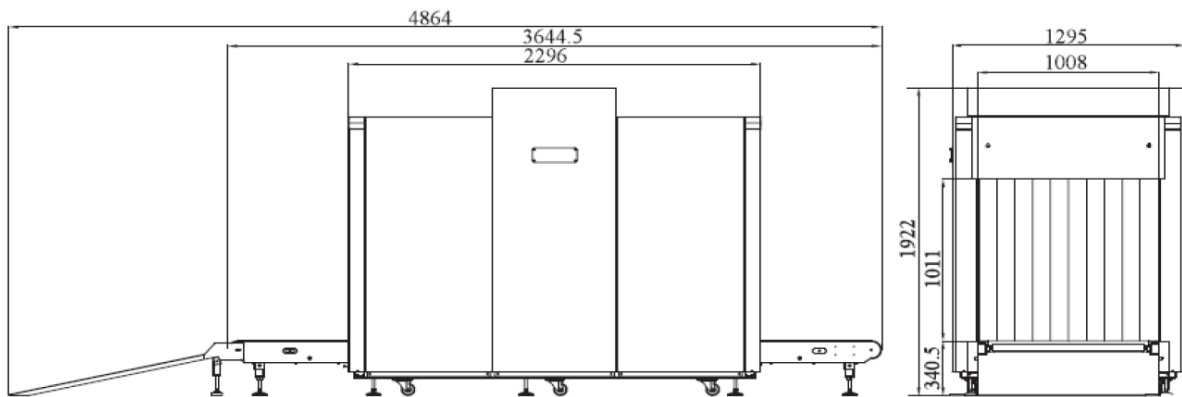

Scanned Images

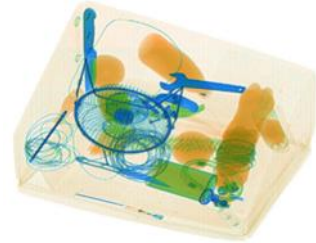

Available Model

NP-SC100100HM

Distributed by

**HIKVISION®**

Headquarters

No.555 Qianmo Road, Binjiang District,
Hangzhou 310051, China
T +86-571-8807-5998
overseasbusiness@hikvision.com

Hikvision USA
T +1-909-895-0400
sales.usa@hikvision.com

Hikvision Australia
T +61-2-8599-4233
salesau@hikvision.com

Hikvision India
T +91-22-28469900
sales@pramahikvision.com

Hikvision Canada
T +1-866-200-6690
sales.canada@hikvision.com

Hikvision Thailand
T +662-275-9949
sales.thailand@hikvision.com

Hikvision Europe
T +31-23-5542770
sales.eu@hikvision.com

Hikvision Italy
T +39-0438-6902
info.it@hikvision.com

Hikvision Brazil
T +55 11 3318-0050
Latam.support@hikvision.com

Hikvision Turkey
T +90 (216)521 7070- 7074
sales.tr@hikvision.com

Hikvision Malaysia
T +601-7652-2413
sales.my@hikvision.com

Hikvision UK & Ireland
T +01628-902140
sales.uk@hikvision.com

Hikvision South Africa
Tel: +27 (10) 0351172
sale.africa@hikvision.com

Hikvision France
T +33(0)1-85-330-450
info.fr@hikvision.com

Hikvision Kazakhstan
T +7-727-9730667
nikia.panfilov@hikvision.ru

Hikvision Vietnam
T +84-974270888
sales.vt@hikvision.com

Hikvision UAE
T +971-4-4432090
salesme@hikvision.com

Hikvision Singapore
T +65-6684-4718
sg@hikvision.com

Hikvision Spain
T +34-91-737-16-55
info.es@hikvision.com

Hikvision Tashkent
T +99-87-1238-9438
uzb@hikvision.ru

Hikvision Hong Kong
T +852-2151-1761
info.hk@hikvision.com

Hikvision Russia
T +7-495-669-67-99
saleru@hikvision.com

Hikvision Korea
T +82-(0)31-731-8817
sales.korea@hikvision.com

Hikvision Poland
T +48-22-460-01-50
info.pl@hikvision.com

Hikvision Indonesia
T +62-21-2933759
Sales.Indonesia@hikvision.com

Hikvision Colombia
sales.colombia@hikvision.com