

QUADRUPLE BEAM SELECTABLE FREQUENCY PHOTOELECTRIC DETECTOR INSTRUCTION MANUAL

DS-PI-Q100/FM
DS-PI-Q150/FM
DS-PI-Q200/FM
DS-PI-Q250/FM



2 SUGGESTIONS FOR INSTALLATION 1



Ensure the sensors line of sight are free from any false alarm sources mounted on a stable and such as bushes, trees, etc. (Pay firm fixing, attention to these as they may change seasonally.)

Ensure the sensors are free from any false alarm sources mounted on a stable and such as bushes, trees, etc. (Pay firm fixing, attention to these as they may change seasonally.)

Ensure strong sunlight or car free from any false alarm sources mounted on a stable and such as bushes, trees, etc. (Pay firm fixing, attention to these as they may change seasonally.)

3 SUGGESTIONS FOR INSTALLATION 2

- Note that here the protection distances refers to the sheet below.
- Height of installation and protection distance.

Model	Protection Distance	Spread of Beam
DS-PI-Q100/FM	100m	3.0m
DS-PI-Q150/FM	150m	4.5m
DS-PI-Q200/FM	200m	6.0m
DS-PI-Q250/FM	250m	7.5m

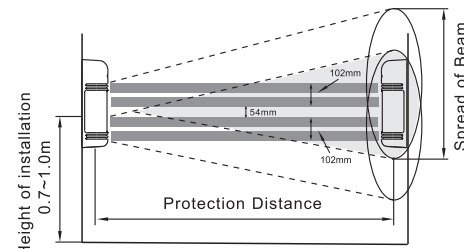

- Direction of installation

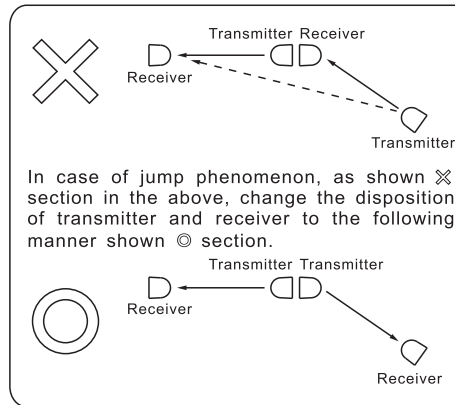
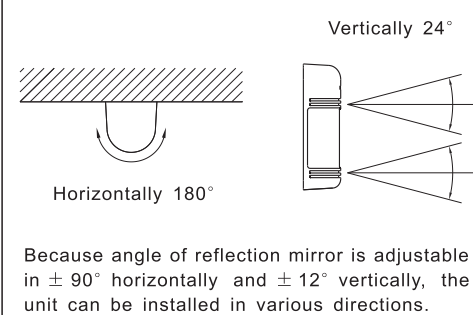

4 INSTALLATION

WALL MOUNT

- Loosen screw holding cover and remove the cover.
- Attach the mounting pattern paper to the wall, mark the installation holes, and make guide holes.
- Break knock-out and pull wire through.

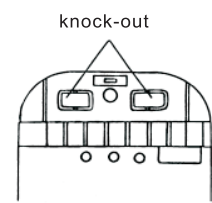
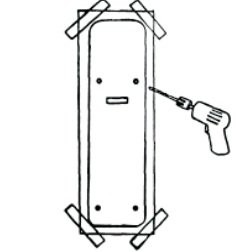
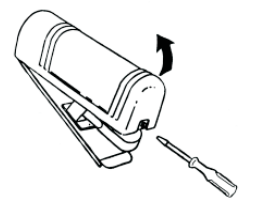

- Attach the unit to the wall.
- Connect wires to the terminal.

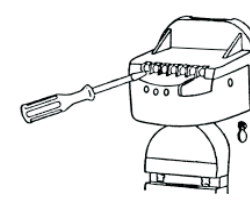
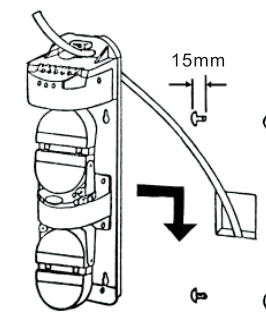

TERMINAL CONFIGURATION

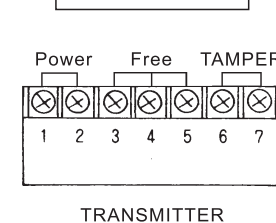
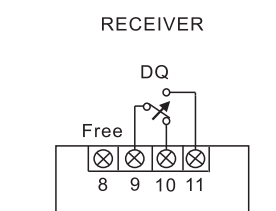
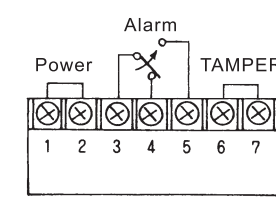

POLE MOUNT

- Pull the wire through the wire hole of the pole.
- Remove the cover in the same manner as done for wall mounting. Attach the unit with pole mount (option) to the pole and the pole-cover (option).

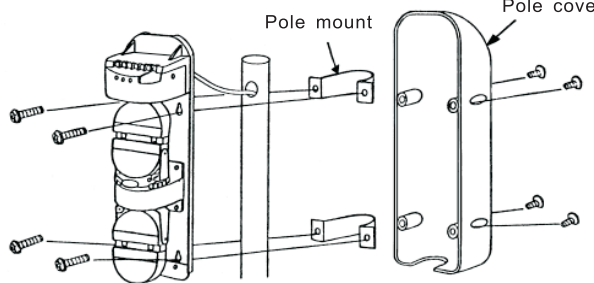
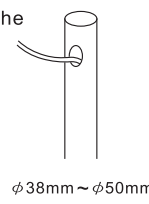

Pole mount back-to-back

- Attach 4 spacers (option) to one unit.
- Attaching temporary and then unit to spacer with screws, put the screws through the pole and fasten the screws.

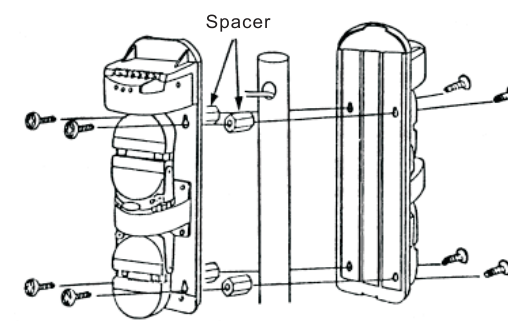

6. Wiring distance

Model	DS-PI-Q100/FM		DS-PI-Q150/FM		DS-PI-Q200/FM		DS-PI-Q250/FM	
	12V	24V	12V	24V	12V	24V	12V	24V
Wire diameter								
0.3mm ² (φ0.6)	110m	950m	105m	900m	100m	850m		
0.5mm ² (φ0.8)	190m	1700m	180m	1600m	170m	1500m		
0.75mm ² (φ1.0)	300m	2700m	280m	2500m	260m	2300m		
1.25mm ² (φ1.2)	430m	3900m	410m	3700m	390m	3500m		

1 PARTS DESCRIPTION

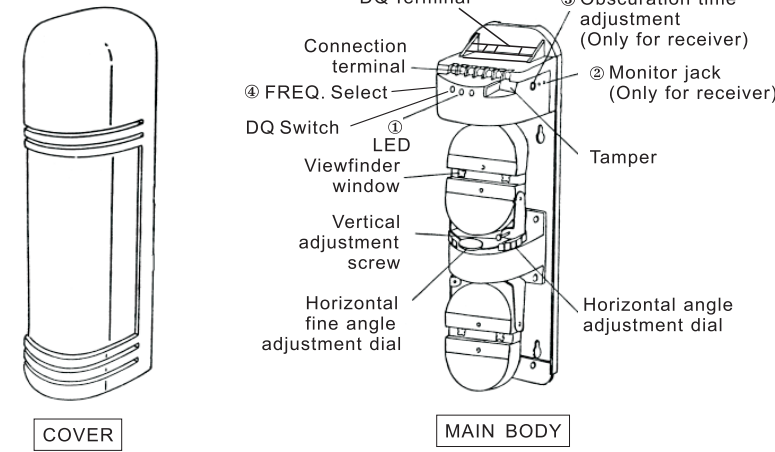

COVER

MAIN BODY

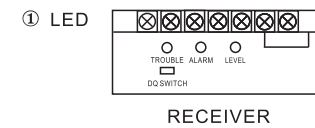

RECEIVER

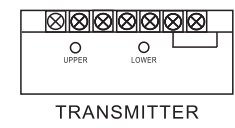

TRANSMITTER



NOTE: Same CH must be selected. Between receiver and Transmitter.

- LED: on when the DQ is operated
- ALARM: on when the alarm is operated
- LEVEL: on in green when optical axis is aligned, on in red when optical axis is not aligned

- UPPER: on when upper beam is transmitted
- LOWER: on when lower beam is transmitted

- Monitor jack: Should be used for making the optimum optical axis adjustment (Refer to 'how to use the monitor jack')
- Obscuration time adjustment: To be used for setting the obscuration time (Refer to 'adjustment of obscuration time')

5 ADJUSTMENT OF OPTICAL AXIS

- It is important to ensure correct optical alignment between the transmitter and receiver for proper operation.

- Remove the filter located on the back of the receiver mirror and attach it to the front face of both the upper and lower receiver mirrors.

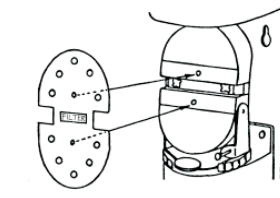

- Look through the viewfinder located on either side of the mirror center with your eyes about 10cm away from the unit.

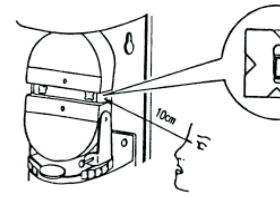

- Adjust vertical adjustment screw, horizontal angle adjustment and horizontal fine angle adjustment so that the sensor can be seen in the center of the viewfinder. During this adjustment, confirm that the green monitor indication lamp of the receiver is on (if the red lamp is on, readjust alignment)

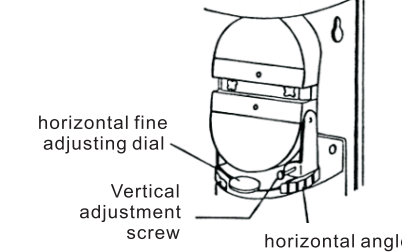

To raise (loosen) / To lower (tighten)

NOTE: After completion of optical adjustment, ensure that both filters on the receiver are replaced to their original position behind the mirrors.

6 ADJUSTMENT OF OBSCURATION

Set the obscuration time of the receiver by adjusting the obscuration time control to the required setting according to the sketch beside. The obscuration time should be set lower to detect faster moving targets, however care should be taken to note the environmental conditions as the obscuration time should be set higher to ignore conditions where there are a lot of birds or wind blown material.

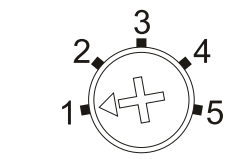

Obscuration time control

Scale 1	Scale 2	Scale 3	Scale 4

7 CONFIRMATION OF OPERATION

After completion of the installation, confirm correct operation by suitable walk test. Refer to the following LED indications during the walk test. Confirm tamper operation prior to replacing covers. Confirm system operation with covers replaced.

	Conditions	Indication
Transmitter	Transmitting	Green LED is on
Receiver	Watching	Alarm indicator is off
	Alarm	Alarm indicator is on

NOTE: Conduct a Walk Test at least once a year

8 TROUBLE SHOOTING GUIDE

Q Symptom	Possible cause	A Remedy
Indication lamp of Transmitter does not light.	Improper voltage of power supply	Check power supply and wiring
Power supply indication Lamp of Receiver does not light.	Improper voltage of power supply	Check power supply and wiring
Alarm indication lamp does not light even when the beams are intercepted.	① Infrared beam from Transmitter is reflected on another object and sent into the Receiver. ② Four beams are not intercepted at the same time. ③ Shorter obscuration time than that set on the obscuration control.	① Remove the reflecting object or change the place for installation and the optical axis direction. ② Check four beams to intercept at the same time. ③ Adjust obscuration time setting to be shorter.
Although alarm LED lights when the beams are intercepted, alarm does not ring.	① Broken wires or short on the signal wires ② Melted bridge on the signal connection (Wrong current on the signal wires)	① Check the wiring. ② It needs to be repaired.
Alarm LED on the Receiver does not turn off.	① Inadequate optical axis. ② Shading objects between the Transmitter and the Receiver. ③ Dirty cover or dirty reflection mirror of the Transmitter and or Receiver. ④ Different CH to be setted between units.	① Readjust the optical axis. ② Remove the shading objects. ③ Clean optics with soft cloth. ④ Re-set the units correctly
Intermittent alarm.	① Bad wiring connection. ② Change of supply voltage. ③ Shading objects moving by wind between the Transmitter and the Receiver. ④ Unstable installation of the sensor unit. ⑤ Incomplete optical axis adjustment. ⑥ Birds and other large flying objects intercept the beam.	① Check the wiring connection. ② Check the voltage (for stabilized supply voltage.) ③ Remove the shading objects or change the place for installation. ④ Fix steadily. ⑤ Readjust the optical axis. ⑥ Readjust the obscuration time to be longer or reposition.

9 SPECIFICATION

Model	DS-PI-Q100/FM	DS-PI-Q150/FM	DS-PI-Q200/FM	DS-PI-Q250/FM
Alarm Distance	100m	150m	200m	250m
Max reaching distance	1000m	1500m	2000m	2500m
Beams NO.	4 beams			
Detecting Way	4 beams Intercepted simultaneously			
Light Source	IR LED			
Response Time	50-700ms			
Channel Choice	4 Channels CH1-CH4			
Alarm Output & DQ Output	FORM C(NC/NO changeable), Contact ratings DC 30V 0.5A max.			
Supply Voltage	DC10.5-28V(non-polarity)			
Recommend supply Voltage	DC 12V or 24V(non-polarity)			
Supply Current	105mA	125mA	140mA	150mA
Operation Temperature Range	-25°C~+55°C			
Tamper Output	Contact Output 1b DC 30V 0.05A max			
Optic axis horizontal adjust	180°(±90°)			
Optic axis vertical adjust	24°(±12°)			
Sight	Peep window			
Strategy to dew/frost	Slit type mask, optional heater			
Other additional functions	Sensitivity to monitor output terminals, OK indicator			
Material	PC front cover; ABS Back Cover			
Attachment	Self-tapping screw: eight, filter: 2 slices			
Dimensions (H×W×D)	353mm×99mm×104mm			
Weight	Around 1970g (Transmitter and Receiver)			

10 OUTLINE DIMENSION

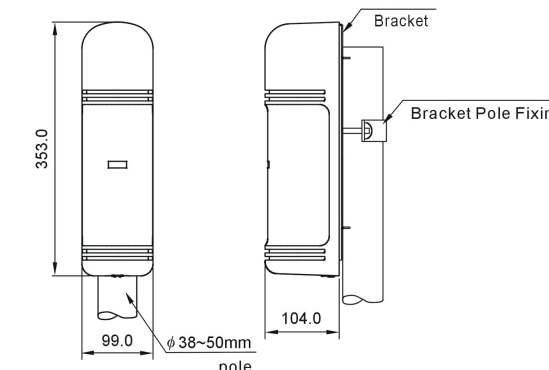

四光束调频主动红外对射 使用说明书

DS-PI-Q100/FM
DS-PI-Q150/FM
DS-PI-Q200/FM
DS-PI-Q250/FM



2 安装上的注意事项1

● 请避免在以下场合安装本探测器



确保在探测器的视线没有任何障碍物，例如灌木丛、树木等。
确保在探测器的视线没有任何障碍物，例如灌木丛、树木等。
确保强力阳光或者汽车的车灯不直接照射到受光器上。（注意这些物体可能随季节而改变）
确保在探测器被安装在一个稳定和坚固的装置物上面。
确保强力阳光或者汽车的车灯不直接照射到受光器上。（建议在离光轴±2°内）

3 安装上的注意事项2

● 警戒距离参照下表

型号	警戒距离	光束扩散
DS-PI-Q100/FM	100m	3.0m
DS-PI-Q150/FM	150m	4.5m
DS-PI-Q200/FM	200m	6.0m
DS-PI-Q250/FM	250m	7.5m

● 安装高度和警戒距离

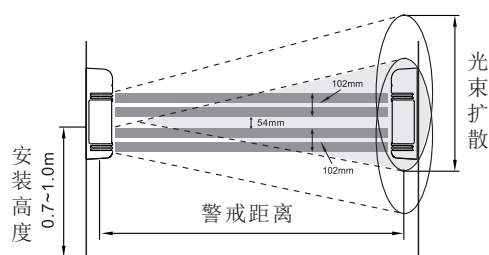

4 安装方法

● 墙壁安装方式

- 松开固定外罩的螺钉，打开外罩
- 将安装模板纸贴在墙上，标出安装孔的位置，钻安装孔。
- 打开配线孔，将导线穿过配线孔。

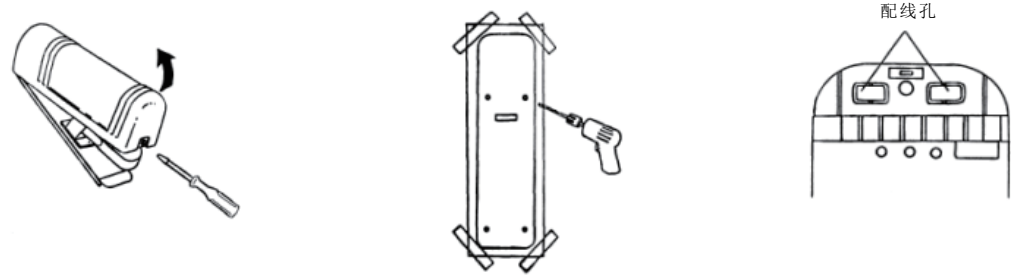

- 将产品固定在墙上。
- 将导线连接到接线端子上。

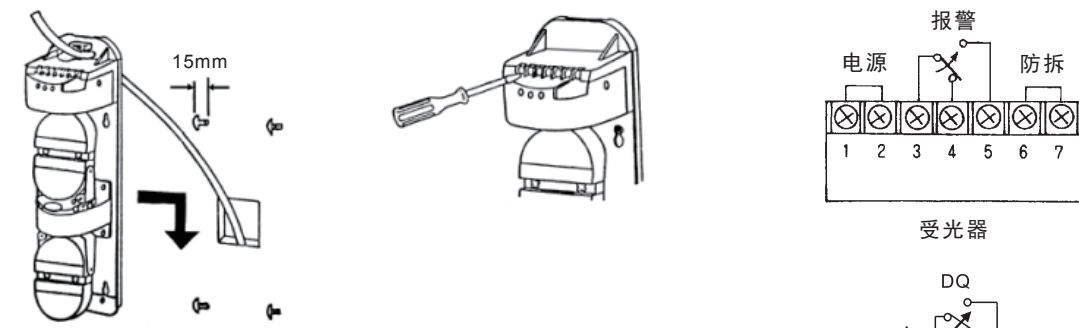

6. 布线距离

线径	DS-PI-Q100/FM		DS-PI-Q150/FM		DS-PI-Q200/FM DS-PI-Q250/FM	
	12V	24V	12V	24V	12V	24V
0.3mm ² (φ0.6)	110m	950m	105m	900m	100m	850m
0.5mm ² (φ0.8)	190m	1700m	180m	1600m	170m	1500m
0.75mm ² (φ1.0)	300m	2700m	280m	2500m	260m	2300m
1.25mm ² (φ1.2)	430m	3900m	410m	3700m	390m	3500m

1 部件名称

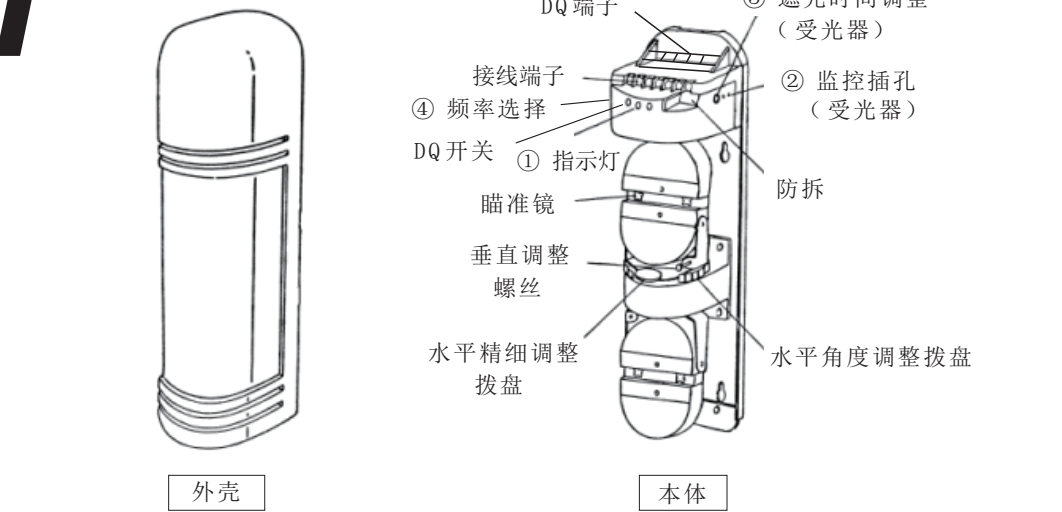

① 指示灯

● TROUBLE 亮:当DQ被监测到时
● ALARM 亮:当报警被监测到时
● LEVEL 绿灯亮:当报警被监测到时

④ 频率选择

● UPPER 亮:当上面的发射端发射时
● LOWER 亮:当下面的发射端发射时

● 注意 受光器和投光器之间必须选择同样的频道

② 监控插孔: 用于最适宜的光轴调整 (参考怎样使用监控插孔)

③ 遮挡时间: 用于设置遮挡时间 (参考调整遮挡时间)

● 安装方向

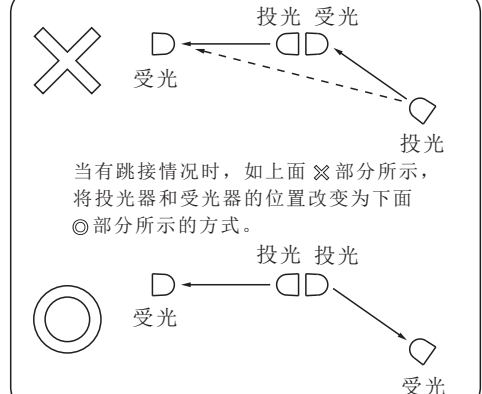
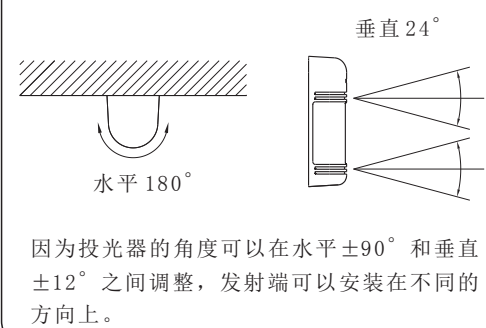

● 固定安装方式

- 穿过立柱上的孔拉出电线。
- 按照墙壁安装相同的方式打开外罩，使用立柱安装配件（选配）将产品固定在立柱和立柱罩配件（选配）上。

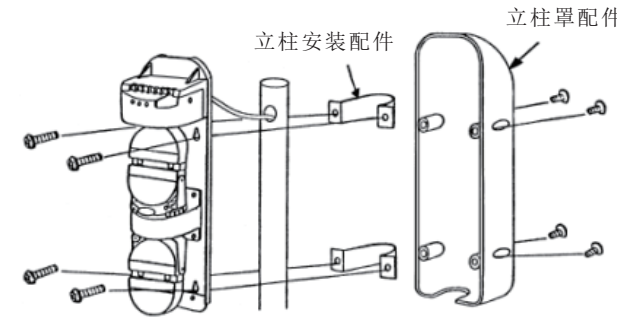

● 背对背安装时参考下图

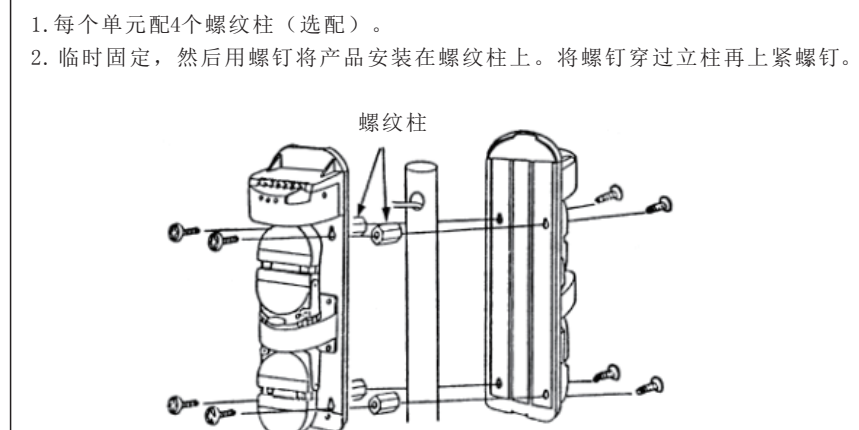

5 光轴调整

● 在投光器和受光器之间确保正确的光路调整对正常使用来说非常重要

- 取下位于受光器镜片后面的滤波器，将它固定在受光器上下镜片的前面。
- 在离产品10cm远的地方，用眼睛透过瞄准镜定位另一端的镜片中心位置。
- 调节垂直调整螺丝、水平角度调整拨盘和水平精细角度调整拨盘，这样就能在瞄准器的中央看到投光器。在调整过程中，确认受光器上的绿色监视指示灯是亮的（如果红色灯亮，重新调整）。

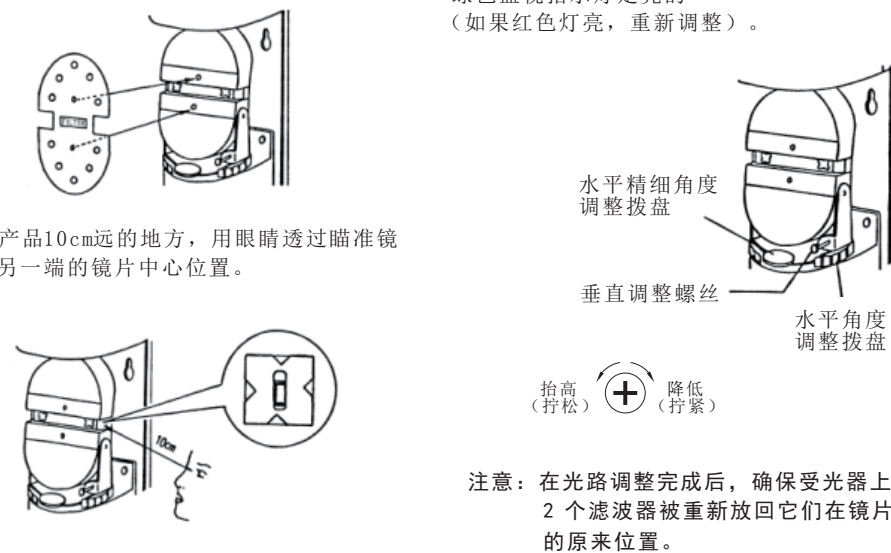

注意：在光路调整完成后，确保受光器上的2个滤波器被重新放回它们在镜片后的原来位置。

6 遮光时间的调整

通过旁边的草图得到要求的设置值，调节“遮光时间的调整”来设置受光器的遮光时间。遮光时间必须设置成较小值以便检测较快的移动目标。然而应该考虑各种环境情况，比如当有鸟或者被风吹动的物体时，遮光时间应该设置为较大值来忽略这些情况。



7 动作确认

在完成安装后，通过恰当的步行测试来确认运行正常。在步行测试时参考下列指示。安装面罩前确认防拆功能运作正常。盖面罩后确认系统运作正常。

	状态	指示
投光器	投光时	绿灯亮
受光器	警戒时	报警指示灯灭
	报警时	报警指示灯亮

注意：步行测试至少每年进行一次

8 异常时的检查

故障现象	可能原因	维修对策
投光器指示灯不亮	电源电压不合适	检查电源和连线
受光器指示灯不亮	电源电压不合适	检查电源和连线
光线被遮断时报警指示灯不亮	① 来自于投光器的红外光束被另一个物体反射进入受光器 ② 四个光束没有同时被遮断 ③ 遮断时间小于遮断控制设定的时间	① 移开反射物体或者改变安装位置和光轴方向 ② 检查四个光束被同时遮断。 ③ 将遮断时间设置调整到较短值
光线被遮断时虽然报警指示灯亮，但报警铃不响	① 信号线开路或者短路 ② 在信号连接端有桥接（信号线上有异常的电流）	① 检查连线 ② 需要返修
在受光器上的报警灯常亮不熄灭	① 光轴调整不恰当 ② 在投光器和受光器之间有障碍物。 ③ 投光器和受光器的外罩或者反射镜上有污物 ④ 投光器和受光器选用了不同的频道	① 重新调整光轴 ② 移开障碍物 ③ 用软布清洁光学部分 ④ 重新进行正确安装
断断续续报警	① 不良配线连接 ② 供电电压变化 ③ 在投光器和受光器有被风吹动的障碍物 ④ 安装不稳固 ⑤ 未完成光轴调整 ⑥ 鸟或者其他大的飞行物遮断光束	① 检查配线连接 ② 检查供电电压（稳定的供电电压） ③ 移开障碍物或者改变安装位置 ④ 安装牢固 ⑤ 重新调整光轴 ⑥ 重新调整遮断时间，把时间调长或重新选置

10 外形尺寸图

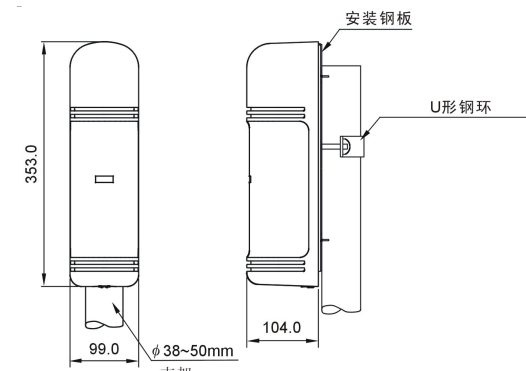

9 技术参数

型号	DS-PI-Q100/FM	DS-PI-Q150/FM	DS-PI-Q200/FM	DS-PI-Q250/FM
警戒距离	100m	150m	200m	250m
最大到达距离	1000m	1500m	2000m	2500m
光束数	4束			
探测方式	4光束同时遮断检知式			
光源	红外LED			
感应速度	50~700ms			
频道选择	4个频道 CH1~CH4			
报警输出&DQ输出	FORM C(NO/NC可转换), 接点容量DC 30V 0.5Amax.			
电源电压	DC10.5~28V(无极性)			
推荐工作电压	DC 12V(无极性)			
消耗电流(DC 12V)	105mA	125mA	140mA	150mA
使用温度范围	-25°C~+55°C			
防拆输出	接点输出1b DC 30V 0.05A max			
光轴调整角度(水平)	180°(±90°)			
光轴调整角度(垂直)	24°(±12°)			
瞄准器	窥视窗			
结露、霜对策	Slit类型面罩, 可选加热器			
其他附加功能	灵敏度监视输出端子, OK指示			
材质	面罩PC树脂; 底壳ABS树脂			
附件	4×30自攻螺丝8颗, 滤波器2片			
外形尺寸	353mm×99mm×104mm			
重量	约1970g (受光器+投光器)			