

DS-TCP140-B(E) Series Parking Camera

Introduction

The DS-TCP140-B(E) series parking camera is applied in the parking guidance and find my car system to detect whether the parking space is occupied or not and recognize the license plate. It is integrated with the parking space status indicator which can indicate red, green, yellow, blue, cyan, and magenta colors. Red indicates the parking space is occupied, green indicates the parking space is available, and blue indicates the parking space is reserved.

The camera can be widely applied in the environment with dark light, such as warehouse, underground garage, bar, garden, etc. to provide HD display.



Key Feature

- Built-in high-performance AI chip, supporting ANPR (accuracy $\geq 99.5\%$), detection of the parking space status (accuracy $\geq 99.99\%$), and smart analysis of crossing over line, motion detection, etc.
- HD 1.3 MP camera, applied in environment with low illumination such as underground garage.
- 3D noise reduction to guarantee clean and exquisite image.
- Smart detection of the parking space status, and smart analysis of crossing over line, motion detection, etc.
- Energy-saving LED with high brightness and low consumption.
- Speed recognition in second accuracy to indicate the parking space status in real time and provide accurate available parking space number.
- Network wiring with easy connection, installation, and maintenance.
- ROI encoding.
- Two RJ45 interfaces, supporting connecting cameras in series, and no power cord is needed.
- Dual-stream.
- Built-in iBeacon module, supporting indoor positioning and navigation with the help of APP. iOS or Android SDK is provided.

Available Model

Model	Description
DS-TCP140-B(E) (2.8 mm)	Single lens, monitoring one or two parking spaces in one direction, built-in parking space status indicator, optional iBeacon module to realize indoor positioning and navigation, external indicator controllable
DS-TCP140-B(E) (4 mm)	

Specification

Camera	
Image Sensor	1/2.7" Progressive Scan CMOS
Min. Illumination	Color: 0.0165 Lux @ (F2.0, AGC ON) B/W: 0.0092 Lux @ (F2.0, AGC ON)
Shutter Speed	1 to 1/100,000 second
Lens	2.8 mm/4 mm (optional)
LED Indicator	In integrated mode, red, green, yellow, blue, cyan, and magenta colors can be indicated. In separation mode, up to 3 external indicators which can indicate red, green, yellow, blue, cyan, and magenta colors can be connected. Supports indicator flashing.
Angle Adjustment	Pan: -30° to 30° Tilt: 0° to 30°
FOV	For 2.8 mm lens: horizontal: 112.1°, vertical: 60°, diagonal: 132.2° For 4 mm lens: horizontal: 86.2°, vertical: 46.7°, diagonal: 103°
Compression	
Video Compression	H.265/H.264/MJPEG
Output Bit Rate	32 Kbps to 16 Mbps
Image	
Image Format	JPEG
Max. Resolution	1280 × 1024
Video Standard	PAL
Frame Rate	30 fps (1280 × 1024)
Image Settings	Brightness, contrast, saturation, white balance, and gain can be adjusted via client or IE browser.
Backlight Compensation	Supported. Areas can be selected.
Network	
Storage	NAS (iSCSI optional) Local storage: guidance terminal HDD
Protocol	TCP/IP, HTTP, DHCP, DNS, DDNS, RTP, RTSP, PPPoE, SMTP, NTP, UPnP, SNMP, FTP, 802.1x, QoS, HTTPS (SIP, SRTP, and IPv6 optional)
General Function	Flashing filter, dual-stream, heartbeat, mirror, password protection, privacy mask, watermark, NTP time synchronization
Smart Function	
Smart Function	Built-in AI deep-learning algorithm, supporting ANPR and parking space detection.
Interface	
Communication Interface	2 × RJ45 10 M/100 M self-adaptive Ethernet interface 1 × power interface 3 × external indicator interface
iBeacon	Standard iBeacon protocol (for -B model)
General	
Working Temperature	-20 °C to 50 °C (-4 °F to 122 °F)
Working Humidity	< 95% (no condensation)
Protection Level	IP54
Power Supply	Hikvision PoE, or 12 to 24 VDC wide-range voltage
Consumption	Max. 6.5 W
Weight	500 g (1.1 lb)

Typical Application

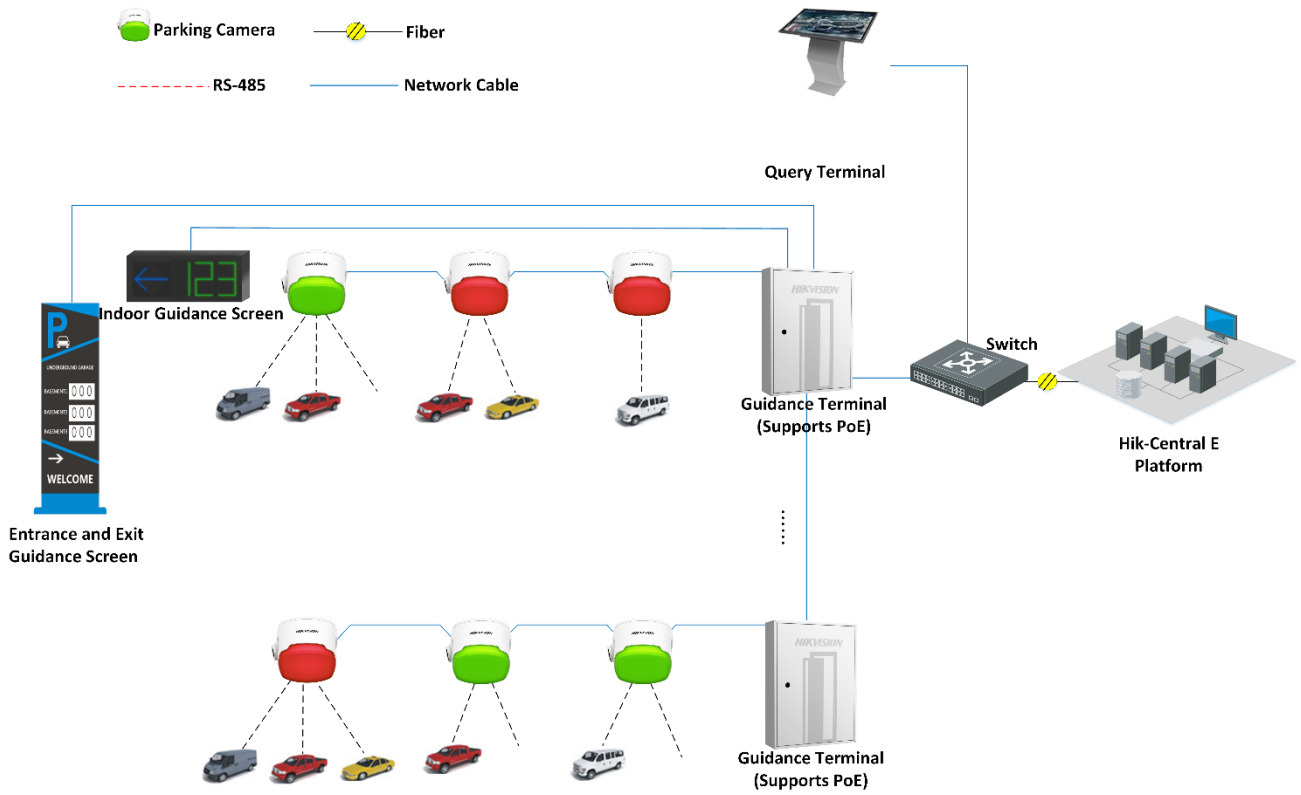

Dimension

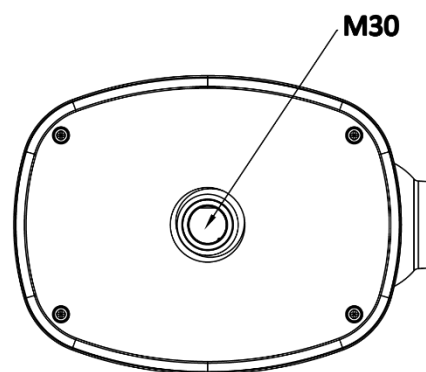
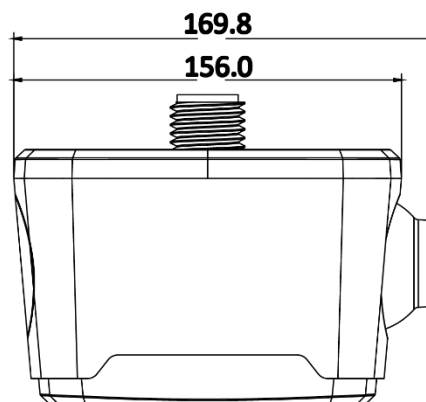
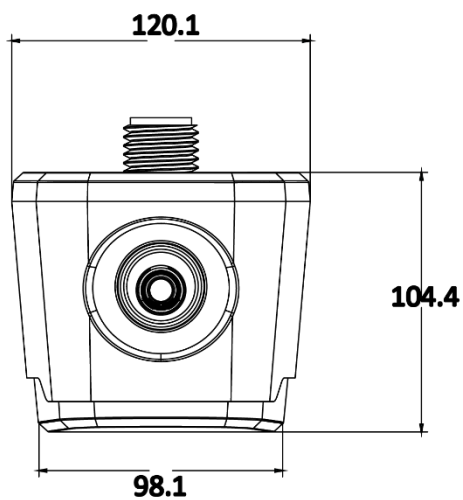

Unit: mm

Headquarters

No.555 Qianmo Road, Binjiang District,
Hangzhou 310051, China
T +86-571-8807-5998
www.hikvision.com



Follow us on social media to get the latest product and solution information.

