



# DS-K3B220X Series Swing Barrier

## Quick Start Guide

UD30049B-A

### 1 System Wiring

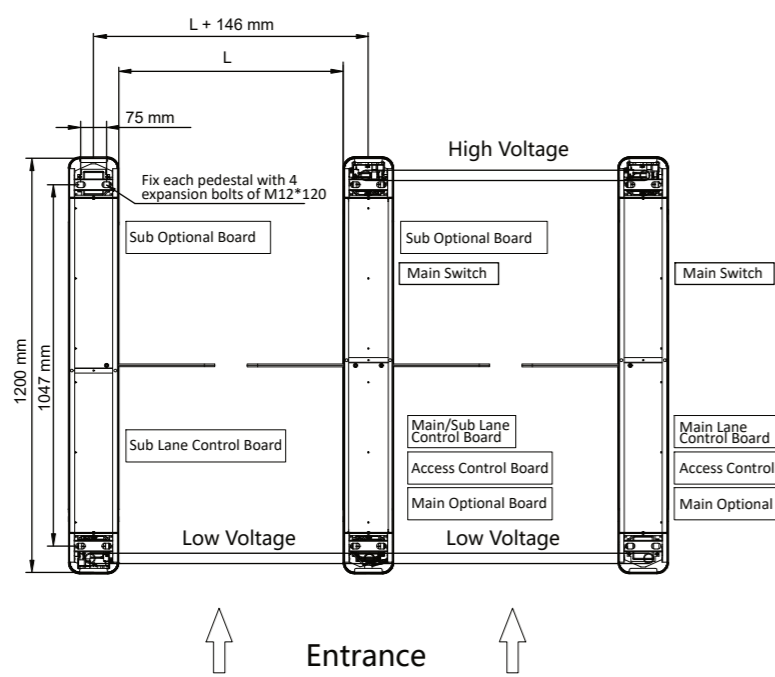

#### Steps:

1. Draw a central line on the installation surface of the left or right pedestal.
  2. Draw other parallel lines for installing the other pedestals.
  3. Slot on the installation surface and dig installation holes according to the hole position. Put 4 expansion bolts of M12\*120 for each pedestal.
  4. Bury cables. Each lane buries 1 high voltage cable and 1 low voltage cable. For details, see the system wiring diagram.
- Notes:**
- The distance between the nearest two lines is  $L + 146$  mm.  $L$  represents the lane width.
  - If you want to bury both of the AC power cord and the low voltage cable, the two cables should be in separated conduits to avoid interference.
  - If more peripherals are required to connect, you should increase the conduit diameter or bury another conduit for the external cables. The external AC power cord should be double-insulated.
  - The network cable must be CAT5e or the network cable has better performance.

### 2 Installation

#### Steps:

1. Place the pedestal above the embedded expansion bolt.
2. Unscrew the lower maintenance door and remove the maintenance door.
3. Place the platen on the expansion bolt and adjust the position of the pedestal to make sure the platen fits well to the bottom of the pedestal.
4. Fasten the nuts of the expansion bolts with a screwdriver (shaft diameter under 7 mm and shank length more than 120 mm) and reinstall the maintenance door.

Scan the QR code to view the user manual.

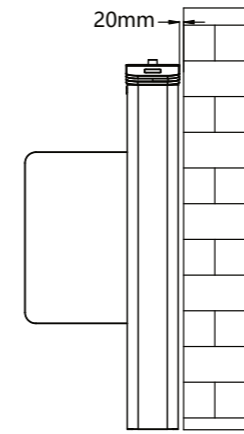

If the installation area is close to the wall, make sure the distance between the pedestal and the wall should be more than 20 mm, or you cannot open the pedestal's top panel.

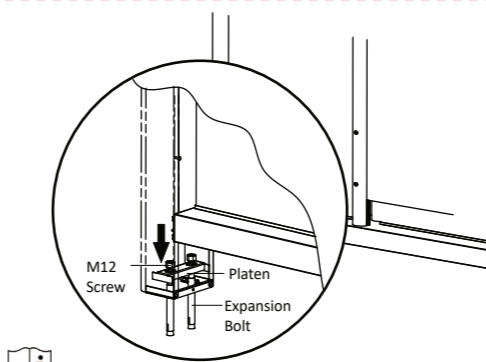

Each pedestal should be fixed with two floor platens.

#### Dimension

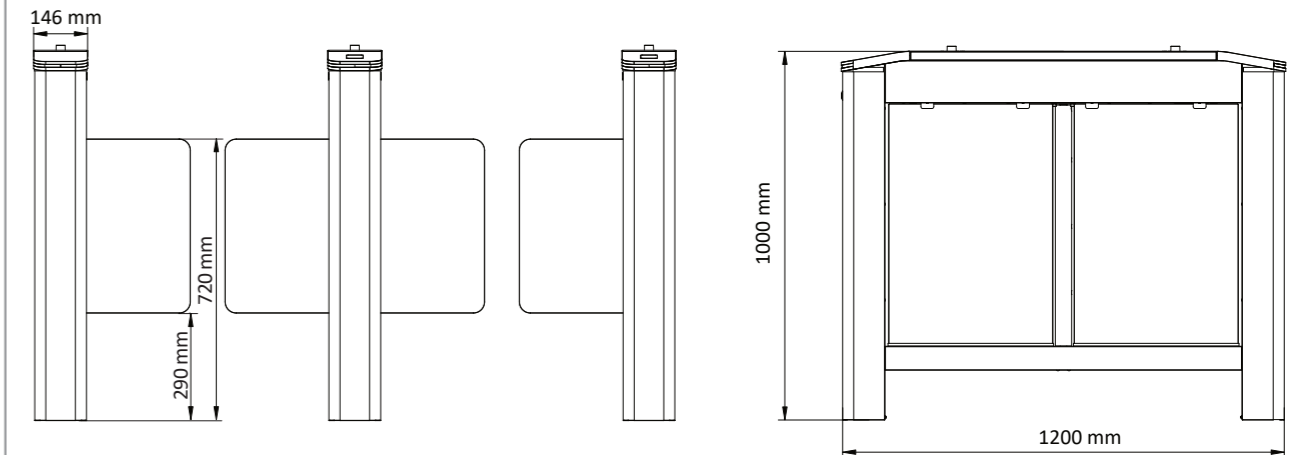

Scan the QR code to view the unboxing video.



### 3 Wiring

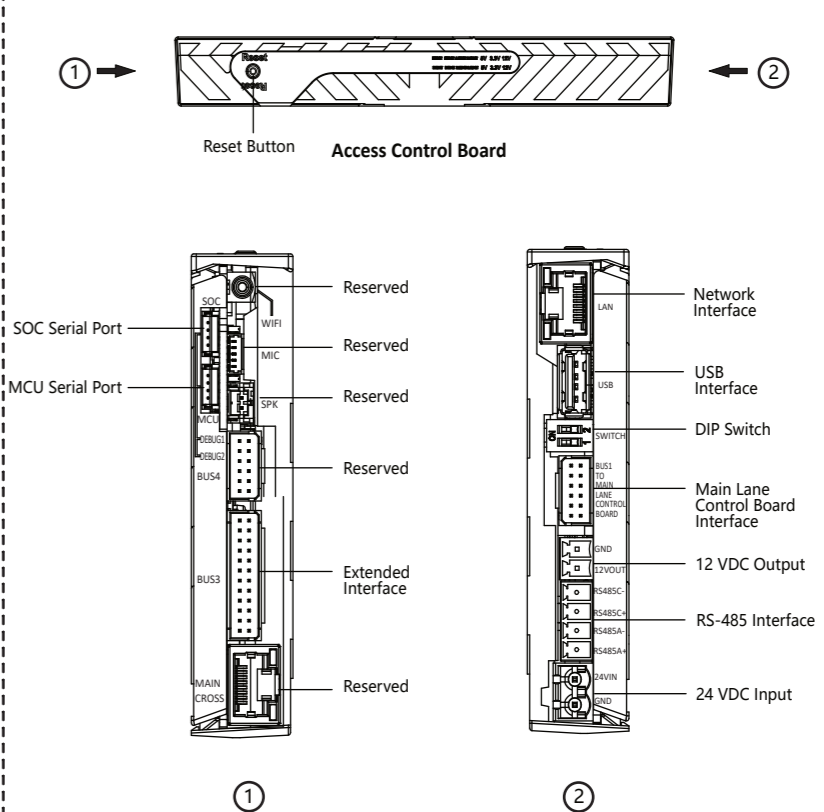
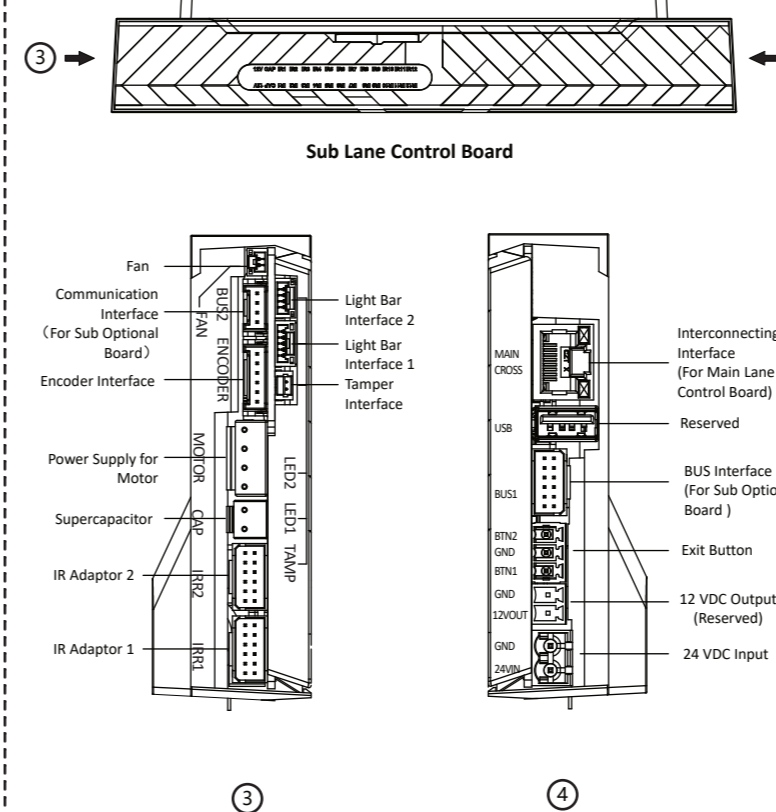
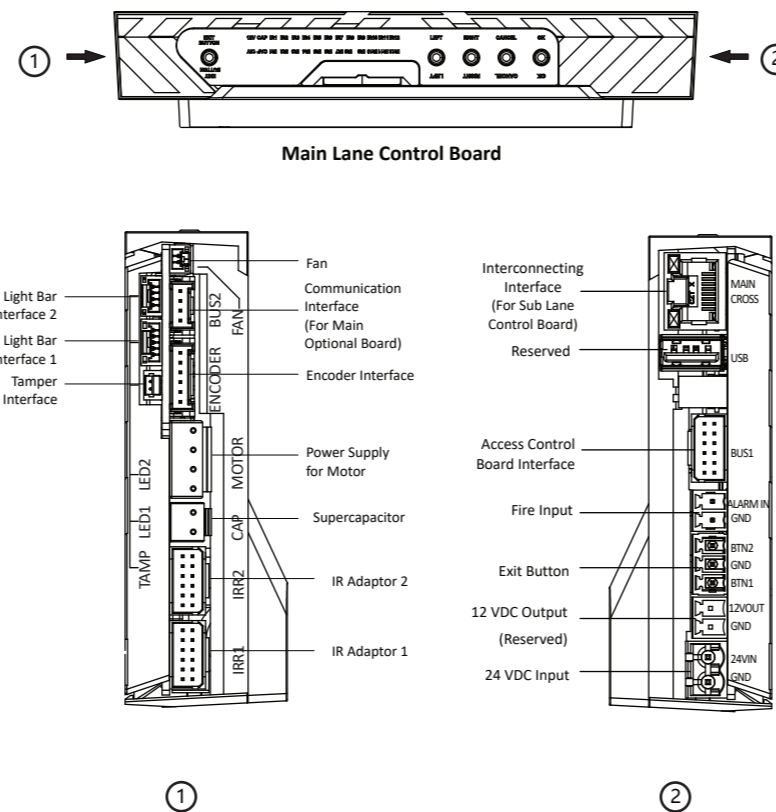
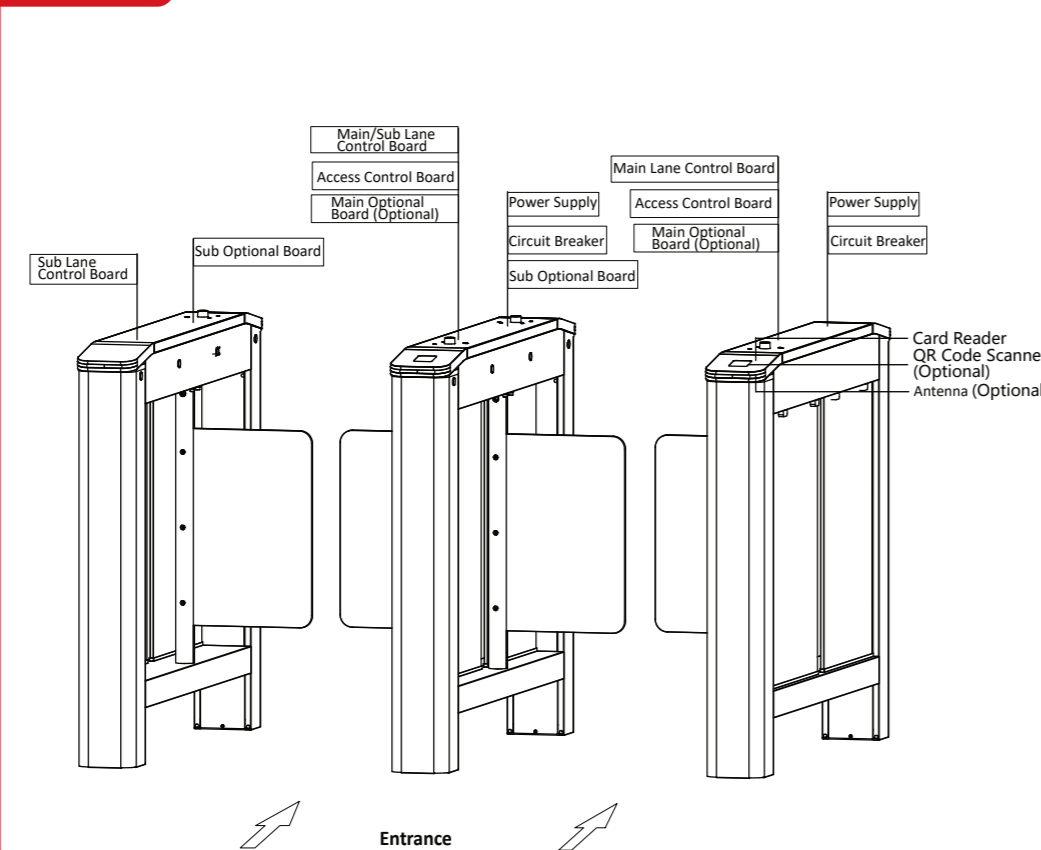

- SOC and MCU serial port are for debugging and maintenance use only.
- Hold the reset button for 5 s, the device will beep for 3 s and start restoring to factory settings.
- RS-485A corresponds to port 5 on web and is for QR code scanner connection by default; RS-485C corresponds to port 7 on web and is for card reader connection by default.
- The DIP switch is for study mode settings and keyfob pairing. Refer to the user manual for details.

©2022 Hangzhou Hikvision Digital Technology Co., Ltd. All rights reserved.  
 About this Manual  
 The Manual includes instructions for using and managing the Product. Pictures, charts, images and all other information hereinafter are for description and explanation only. The information contained in the Manual is subject to change, without notice, due to firmware updates or other reasons. Please find the latest version of this Manual at the Hikvision website (https://www.hikvision.com/). Please use this Manual with the guidance and assistance of professionals trained in supporting the Product.  
 Trademarks  
 HIKVISION and other Hikvision's trademarks and logos are the properties of Hikvision in various jurisdictions. Other trademarks and logos mentioned are the properties of their respective owners.  
 Disclaimer  
 TO THE MAXIMUM EXTENT PERMITTED BY APPLICABLE LAW, THIS MANUAL AND THE PRODUCT DESCRIBED, WITH ITS HARDWARE, SOFTWARE AND FIRMWARE, ARE PROVIDED "AS IS" AND "WITH ALL FAULTS AND ERRORS". HIKVISION MAKES NO WARRANTIES, EXPRESS OR IMPLIED, INCLUDING WITHOUT LIMITATION, MERCHANTABILITY, SATISFACTORY QUALITY, OR FITNESS FOR A PARTICULAR PURPOSE. THE USE OF THE PRODUCT BY YOU IS AT YOUR OWN RISK. IN NO EVENT WILL HIKVISION BE LIABLE TO YOU FOR ANY SPECIAL, CONSEQUENTIAL, INCIDENTAL, OR INDIRECT DAMAGES, INCLUDING, AMONG OTHERS, DAMAGES FOR LOSS OF BUSINESS PROFITS, BUSINESS INTERRUPTION, OR LOSS OF DATA, CORRUPTION OF SYSTEMS, OR LOSS OF DOCUMENTATION, WHETHER BASED ON BREACH OF CONTRACT, TORT (INCLUDING NEGLIGENCE), PRODUCT LIABILITY, OR OTHERWISE, IN CONNECTION WITH THE USE OF THE PRODUCT, EVEN IF HIKVISION HAS BEEN ADVISED OF THE POSSIBILITY OF SUCH DAMAGES OR LOSS.  
 YOU AGREE TO USE THIS PRODUCT IN COMPLIANCE WITH ALL APPLICABLE LAWS, AND YOU ARE SOLELY RESPONSIBLE FOR ENSURING THAT YOUR USE CONFORMS TO THE APPLICABLE LAW, ESPECIALLY YOU ARE RESPONSIBLE FOR USING THIS PRODUCT IN A MANNER THAT DOES NOT INFRINGE ON THE RIGHTS OF THIRD PARTIES, INCLUDING WITHOUT LIMITATION, RIGHTS OF PUBLICITY, INTELLECTUAL PROPERTY RIGHTS, OR DATA PROTECTION AND OTHER PRIVACY RIGHTS. YOU SHALL NOT USE THIS PRODUCT FOR ANY PROHIBITED END-USES, INCLUDING THE DEVELOPMENT OR PRODUCTION OF WEAPONS OF MASS DESTRUCTION, THE DEVELOPMENT OR PRODUCTION OF CHEMICAL, BIOLOGICAL WEAPONS, ANY ACTIVITIES IN THE CONTEXT RELATED TO ANY NUCLEAR EXPLOSIVE OR UNSAFE NUCLEAR FUEL-CYCLE, OR IN SUPPORT OF HUMAN RIGHTS ABUSES. IN THE EVENT OF ANY CONFLICTS BETWEEN THIS MANUAL AND THE APPLICABLE LAW, THE LATTER PREVAILS.  
 Data Protection  
 During the use of device, personal data will be collected, stored and processed. To protect data, the development of Hikvision devices incorporates privacy by design principles. For example, for device with facial recognition features, biometrics data is stored in your device with encryption method; for fingerprint device, only fingerprint template will be saved, which is impossible to reconstruct a fingerprint image. As data controller, you are advised to collect, store, process and transfer data in accordance with the applicable data protection laws and regulations, including without limitation, conducting security controls to safeguard personal data, such as implementing administrative and physical security controls, conduct periodic reviews and assessments of the effectiveness of your security controls.

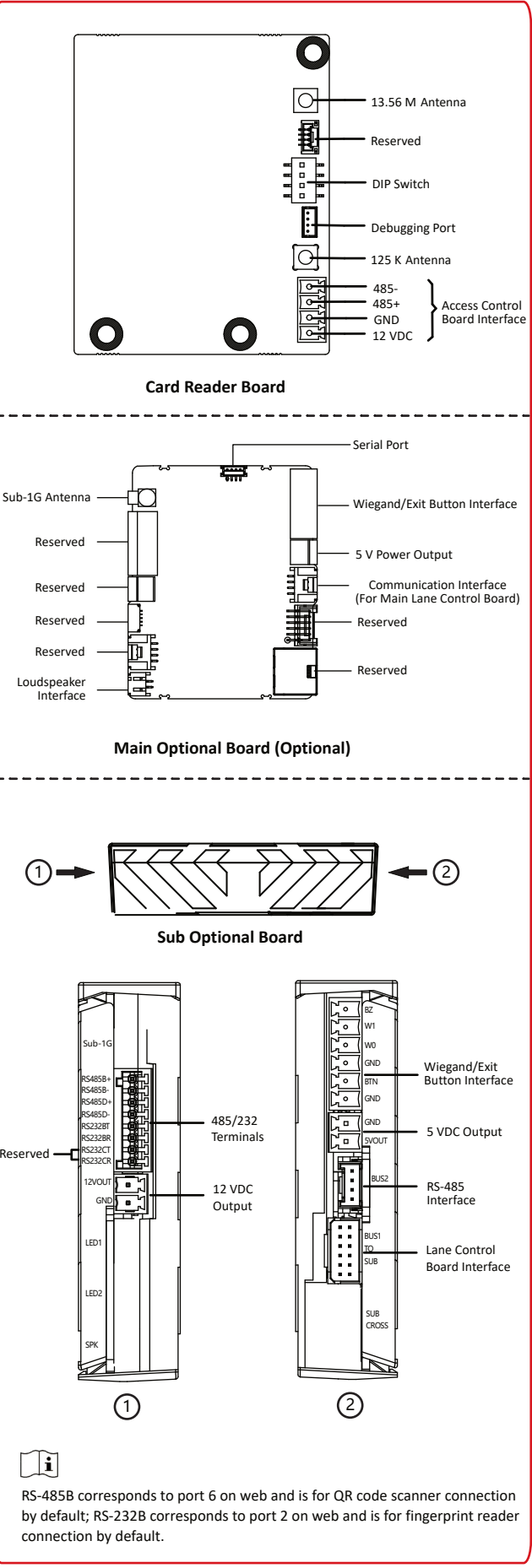

### 4 Wiring Diagram

- The power cable from power supply to the main lane control board has been connected. You will need to prepare the 14AWG power cable to connect the AC power input to power supply.
- The supplied 2 interconnecting cables need connecting on-site: 1. 24 V power cable of 14 AWG. The cable is 2.5 m in length and put inside the right/middle pedestal at the exit. 2. UTP-5e Communication cable. The cable is 3 m in length and put inside the package of the right/middle pedestal.
- The ① and ② or ③ and ④ refer to the two sides of a same board.
- Barrier opens at the entrance/exit: connect to BTN1/BTN2 and GND.

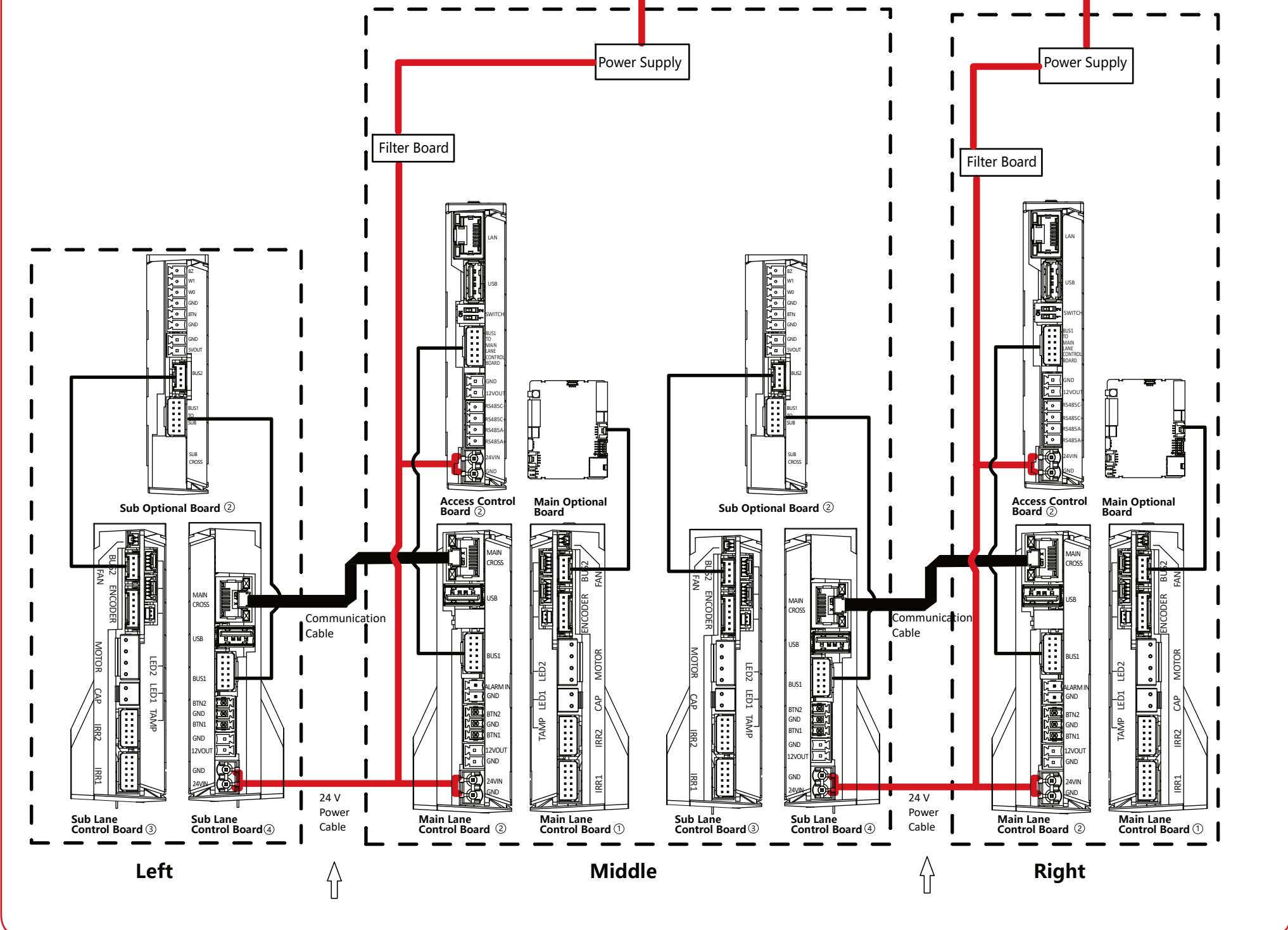

### 5 Button Description

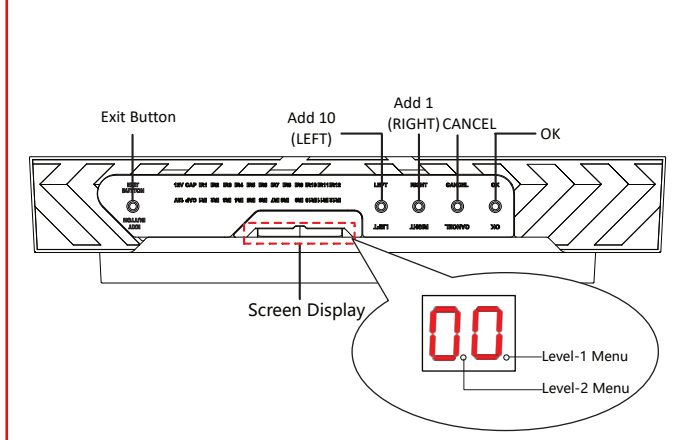

### 5 Button Description

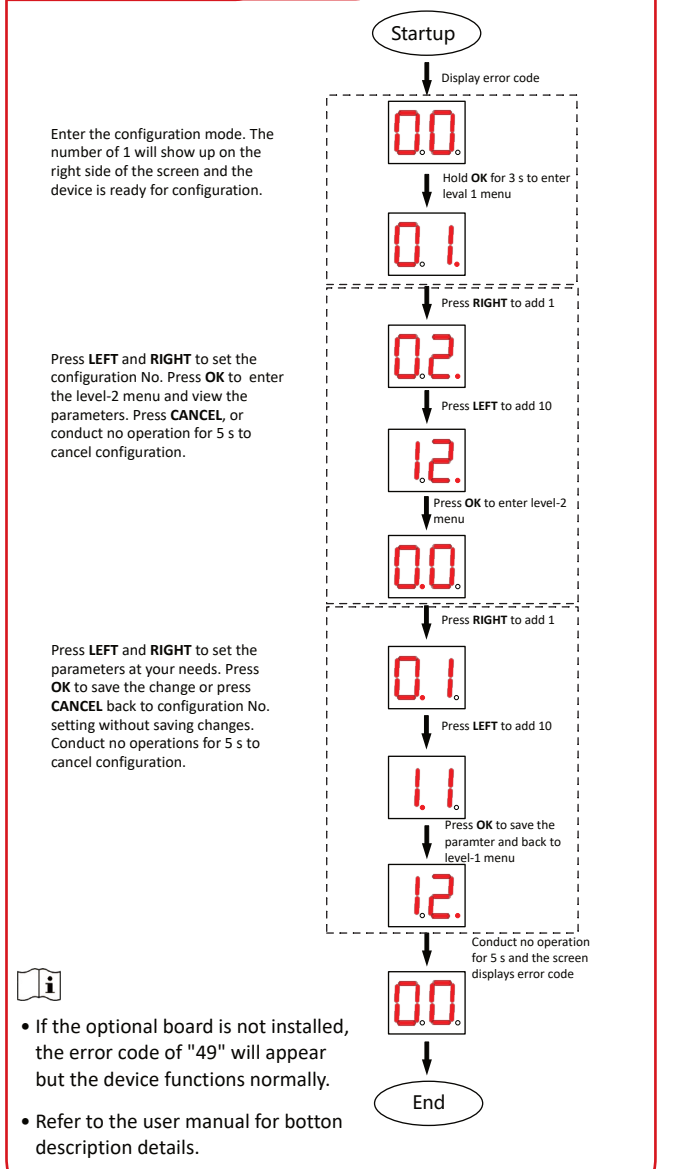

### Regulatory Information

**FCC Information**  
Please take attention that changes or modification not expressly approved by the party responsible for compliance could void the user's authority to operate the equipment.  
FCC compliance: This equipment has been tested and found to comply with the limits for a Class B digital device, pursuant to part 15 of the FCC Rules. These limits are designed to provide reasonable protection against harmful interference in a residential installation. This equipment generates, uses and can radiate radio frequency energy and, if not installed and used in accordance with the instructions, may cause harmful interference to radio communications. However, there is no guarantee that interference will not occur in a particular installation. If this equipment does cause harmful interference to radio or television reception, which can be determined by turning the equipment off and on, the user is encouraged to try to correct the interference by one or more of the following measures:  
—Reorient or relocate the receiving antenna.  
—Increase the separation between the equipment and receiver.  
—Connect the equipment into an outlet on a circuit different from that to which the receiver is connected.  
—Consult the dealer or an experienced radio/TV technician for help.  
This equipment should be installed and operated with a minimum distance 20cm between the radiator and your body.  
FCC Conditions  
This device complies with part 15 of the FCC Rules. Operation is subject to the following two conditions:  
1. This device may not cause harmful interference.  
2. This device must accept any interference received, including interference that may cause undesired operation.

**CE**  
This product and - if applicable - the supplied accessories too are marked with "CE" and comply therefore with the applicable harmonized European standards listed under the RE Directive 2014/53/EU, the EMC Directive 2014/30/EU, the RoHS Directive 2011/65/EU.

**2006/66/EC (battery directive):** This product contains a battery that cannot be disposed of as unsorted municipal waste in the European Union. See the product documentation for specific battery information. The battery is marked with this symbol, which may include lettering to indicate cadmium (Cd), lead (Pb), or mercury (Hg). For proper recycling, return the battery to your supplier or to a designated collection point. For more information see: [www.recyclethis.info](http://www.recyclethis.info)

**2012/19/EU (WEEE directive):** Products marked with this symbol cannot be disposed of as unsorted municipal waste in the European Union. For proper recycling, return this product to your local supplier upon the purchase of equivalent new equipment, or dispose of it at designated collection points. For more information see: [www.recyclethis.info](http://www.recyclethis.info)

### Safety Instructions

- Warning**
- In the use of the product, you must be in strict compliance with the electrical safety regulations of the nation and region.
  - Do not connect several devices to one power adapter as adapter overload may cause over-heat or fire hazard.
  - If smoke, odors or noise rise from the device, turn off the power at once and unplug the power cable, and then please contact the service center.
  - The socket-outlet shall be installed near the equipment and shall be easily accessible.
  - 1. Do not ingest battery. Chemical burn hazard!
  - 2. This product contains a coin/button cell battery. If the coin/button cell battery is swallowed, it can cause severe internal burns in just 2 hours and can lead to death.
  - 3. Keep new and used batteries away from children.
  - 4. If the battery compartment does not close securely, stop using the product and keep it away from children.
  - 5. If you think batteries might have been swallowed or placed inside any part of the body, seek immediate medical attention.
  - 6. CAUTION: Risk of explosion if the battery is replaced by an incorrect type.
  - 7. Improper replacement of the battery with an incorrect type may defeat a safeguard (for example, in the case of some lithium battery types).
  - 8. Do not dispose of the battery into fire or a hot oven, or mechanically crush or cut the battery, which may result in an explosion.
  - 9. Do not leave the battery in an extremely high temperature surrounding environment, which may result in an explosion or the leakage of flammable liquid or gas.
  - 10. Do not subject the battery to extremely low air pressure, which may result in an explosion or the leakage of flammable liquid or gas.
  - 11. Dispose of used batteries according to the instructions.
- Caution**
- Do not drop the device or subject it to physical shock, and do not expose it to high electromagnetic radiation. Avoid the equipment installation on vibrations surface or places subject to shock (ignorance can cause equipment damage).
  - Do not place the device in extremely hot (refer to the specification of the device for the detailed operating temperature), cold, dusty or damp locations, and do not expose it to high electromagnetic radiation.
  - Exposing the equipment to direct sun light, low ventilation or heat source such as heater or radiator is forbidden (ignorance can cause fire danger). The device cover for indoor use shall be kept from rain and moisture.
  - Exposing the equipment to direct sun light, low ventilation or heat source such as heater or radiator is forbidden (ignorance can cause fire danger).
  - Please use a soft and dry cloth when clean inside and outside surfaces of the device cover, do not use alkaline detergents.
  - Biometric recognition products are not 100% applicable to anti-spoofing environments. If you require a higher security level, use multiple authentication modes.
  - The serial port of the equipment is used for debugging only.
  - Wall Mounting: Install the equipment according to the instructions in this manual. To prevent injury, this equipment must be securely attached to the floor/wall in accordance with the installation instructions.
  - Improper use or replacement of the battery may result in hazard of explosion. Replace with the same or equivalent type only. Dispose of used batteries according to the instructions provided by the battery manufacturer.
  - This bracket is intended for use only with equipped devices. Use with other equipment may result in instability causing injury.
  - This equipment is for use only with equipped bracket. Use with other (carts, stands, or carriers) may result in instability causing injury.