

## DS-D4429RI-CBF LED Display



- Cabinet is die-casting aluminum integrated.
- Modularized design: LED cabinet consists of frame, power box and modules. For different pixel pitches, they can share same power box and frame.
- Seamless connection: There are four locks totally on each cabinet. They can lock cabinets well for seamless splicing.
- One end of the power cables between two cabinets is fixed. Such design can help to realize fast installation and disassembly.
- Labor saving: One single person can manage installation easily, which can save labor cost.
- Screen can be both inward and outward curve. (optional)
- 90° connection is available. (needs customization)
- Anti-collision design: There are protectors at the four corners of the cabinets, which can help to protect lamps effectively during transportation. (needs customization)
- Multi-application scenarios: It is widely used in concerts, events, opera houses, theaters, hotels, auditorium, multi-function hall, lecture hall, high-end entertainment venues, and so forth.

## ▪ Specification

	Model	DS-D4429RI-CBF
<b>Cabinet</b>	Pixel Configuration	SMD 3-in-1
	Pixel Pitch Category	P2.97
	Pixel Pitch	2.97 mm
	Modules Component	2 × 2
	Dimensions (W × H × D)	500 (H) × 500 (W) × 53 (D) mm (19.685" × 19.685" × 2.087") (not including modules) 500 (H) × 500 (W) × 70.6 (D) mm (19.685" × 19.685" × 2.78") (including modules)
	Resolution	168 × 168
	Area	0.25 m <sup>2</sup>
	Weight	6.8 Kg (14.99 lb)
	Pixel Density	112896 dots/m <sup>2</sup>
	Lamp Board Housing	No housing
	Cabinet Material	Die-casting aluminum
	Maintenance Method	Front and rear maintenance
	Cabinet Flatness	0.1 mm
	Protection Level	Front protection level IP40
<b>Display</b>	White Balance Brightness	≥ 800 cd/m <sup>2</sup>
	Color Temperature	6500 K to 10000 K adjustable
	Viewing Angle	Horizontal 160°, vertical 140°
	Contrast Ratio	≥ 3000:1
	Color Uniformity	≤ ± 0.003Cx, Cy
	Brightness Uniformity	≥ 97%
<b>Processing Performance</b>	Driving Method	Constant current driving
	Frame Frequency	60 Hz
	Refresh Rate	Up to 3840 Hz
	Grey Level	Up to 16 bit
	Display Color	281 trillion
<b>Power</b>	Power Supply	110 V/220 V
	Max. Consumption	≤ 600 W/m <sup>2</sup>
	Average Consumption	≤ 200 W/m <sup>2</sup>
<b>Working Environment</b>	Working Temperature	-10~40 °C
	Working Humidity	10%~80% RH
	Storage Humidity	10%~85% RH
	Storage Temperature	-20~60 °C
<b>General</b>	Gross Weight	90 Kg (198.42 lb) ± 10%
	Package Dimensions (W × H × D)	840 (L) × 700 (W) × 570 (H) mm (33.07" × 27.56" × 22.44" ) (8-in-1 flight case)
	Lifespan	Lamp 100,000 hours

**▪ Available Model**

DS-D4429RI-CBF

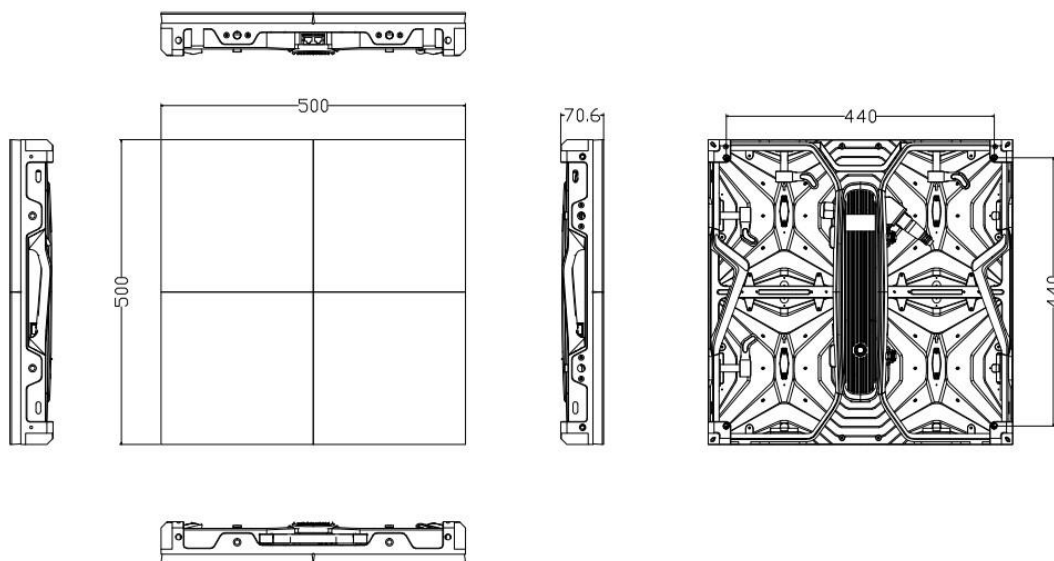
**▪ Dimension****Headquarters**

No.555 Qianmo Road, Binjiang District,  
Hangzhou 310051, China  
T +86-571-8807-5998  
www.hikvision.com

Follow us on social media to get the latest product and solution information.



Hikvision



HikvisionHQ



HikvisionHQ



Hikvision\_Global

Hikvision  
Corporate Channel

hikvisionhq

