

## DS-2TS16-50VI/W Handheld Thermal & Optical Bi-spectrum Binocular



Hikvision DS-2TS16-50VI/W Handheld Thermal & Optical Bi-spectrum Binocular is equipped with ultra-low light optical detector, 640 × 512 thermal detector, 1024×768 OLED display and eyepiece with large field of view. The device can quickly discover and locate hiding objects even under extreme environment, such as smoke, fog, rain and snow. It can be widely applied to scenarios like patrol, law enforcement, search and rescue, drug enforcement, anti-smuggling and suspect capture.

### Key Feature

- High sensitivity thermal module with 640 × 512 resolution
- NETD < 40 mk (@25°C, F# = 1.0) Leading thermal image processing technology: Adaptive AGC, DDE, 3D DNR
- High quality optical module with 1280 × 960 resolution
- Automatic OLED backlight
- Video recording, replay, snapshot, and search (users can review event on device)
- Wi-Fi hot spot, GPS, cursor display
- Up to 7 hours continuous operation

## ▪ Specification

Thermal Module	
Image Sensor	Vanadium Oxide Uncooled Focal Plane Arrays
Max. Resolution	640 × 512
Pixel Pitch	17 μm
Response waveband	8 μm to 14 μm
NETD	< 40mk (@25°C, F# = 1.0)
Lens (focal length)	50 mm
Field of View	12.42° × 9.95°
Aperture	F1.0
MRAD (IFOV)	0.34
Digital Zoom	4×
Image Display	
Thermal/Optical Mode	Thermal view, B/W optical view, image fusion view are selectable
Image Fusion	Color fusion, B/W fusion
Monitor	0.39-inch, OLED, 1024 × 768
Palettes	Black hot, white hot
Optical Module	
Max. Resolution	1280 × 960@25fps
Image Sensor	1/3" Progressive Scan CMOS
Min. Illumination	B/W: 0.001 lux @ (F1.0 , AGC On )
Lens (focal length)	12mm, Manual focus
Image Enhancement	3D DNR, Adaptive AGC
Smart	
Object Highlight	Yes
Cursor Display	A cursor shows in the view for roughly measuring distance from the target.
Automatic Backlight	The OLED backlight automatically turns off if no human eyes are detected.
System	
Record Video	On-board video recording
Snapshot	On-board image capturing
Video Replay	Yes
Picture Search	Yes
Wi-Fi	Yes
GPS	Yes
Storage	Built-in memory module (32 GB)

Power Supply	
Battery Type	Four 18650 batteries, requires 5 hours to be fully charged
Battery Operating Time	≥ 7h
Battery Capacity Display	Yes
General	
Power	5 VDC/2 A
Weight	< 1.0 kg (2.20 lb)
Protection level	IP67
Dimension (L x W x H)	164 mm × 182 mm × 74.3 mm (6.46" × 7.17" × 2.93")
Cable Output	Aviation plug: connecting to BNC, DB9, and USB
Accessories (Supplied)	Battery charger, battery charger power cable, wiping cloth, two wrist straps, User manual, aviation plug cable, eight batteries
Mounting	UNC 1/4"-20
Working Temperature	-30°C to 55°C (-22°F to 131°F)

## Wide Range Coverage for Different Specifications

**Note:** The table below is only for reference, the performance varies from model to model, and the specific data is based on 17 μm pixel pitch.

Lens (focal length)	50 mm
Detection range (Vehicles)	4510 m
Detection range (Humans)	1471 m
Recognition range (Vehicles)	1127 m
Recognition range (Humans)	368 m
Identification range (Vehicles)	564 m
Identification range (Humans)	184 m

## Available Model

DS-2TS16-50VI/W

**Dimensions**

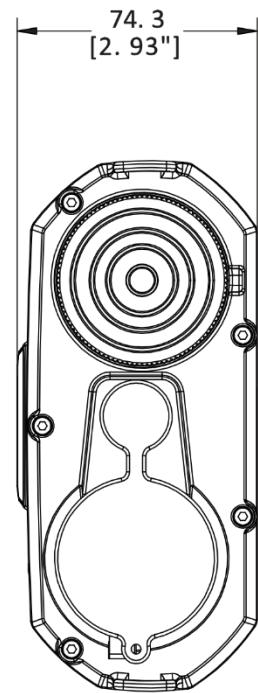
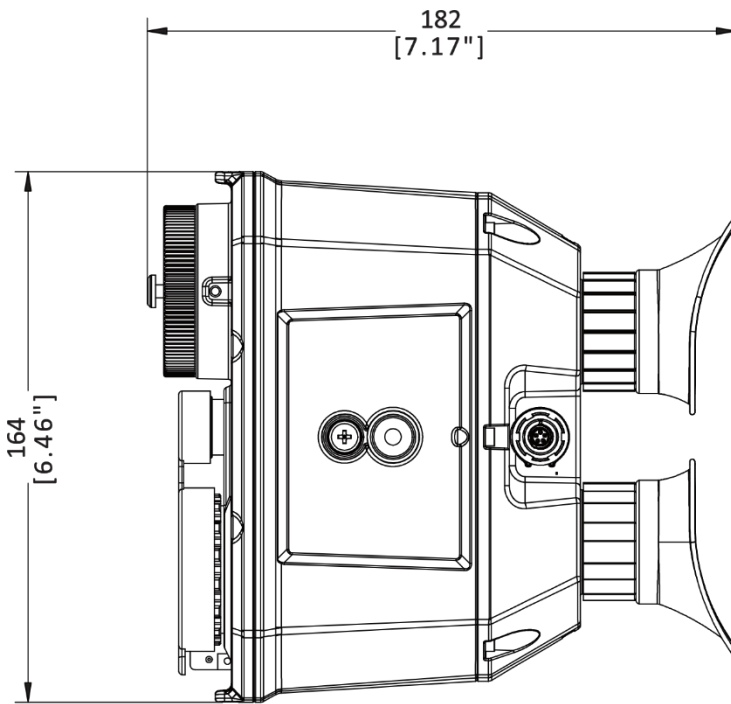

**Unit: mm [Inch]**

COMPLIANCE NOTICE: The thermal series products might be subject to export controls in various countries or regions, including without limitation, the United States, European Union, United Kingdom and/or other member countries of the Wassenaar Arrangement. Please consult your professional legal or compliance expert or local government authorities for any necessary export license requirements if you intend to transfer, export, re-export the thermal series products between different countries.

**Headquarters**

No.555 Qianmo Road, Binjiang District,  
Hangzhou 310051, China  
T +86-571-8807-5998  
www.hikvision.com



Follow us on social media to get the latest product and solution information.

